

# PLIANT BELLOWS™

Expansion Joints  
ENRICHED FOR FLEXIBILITY

By  
Flexoresist Technologies Pvt. Ltd.

ENRICHED  
FOR

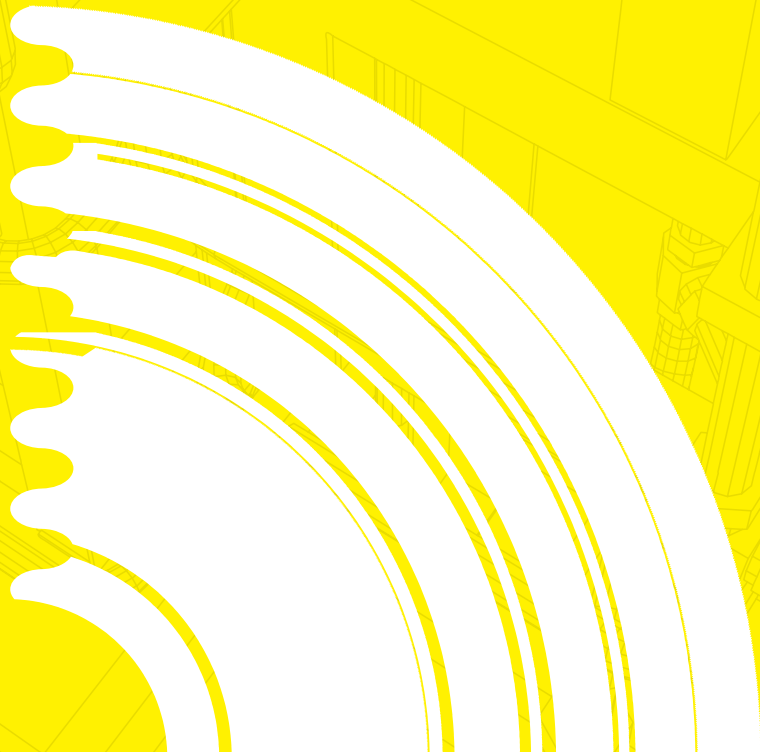

FLEXIBILITY



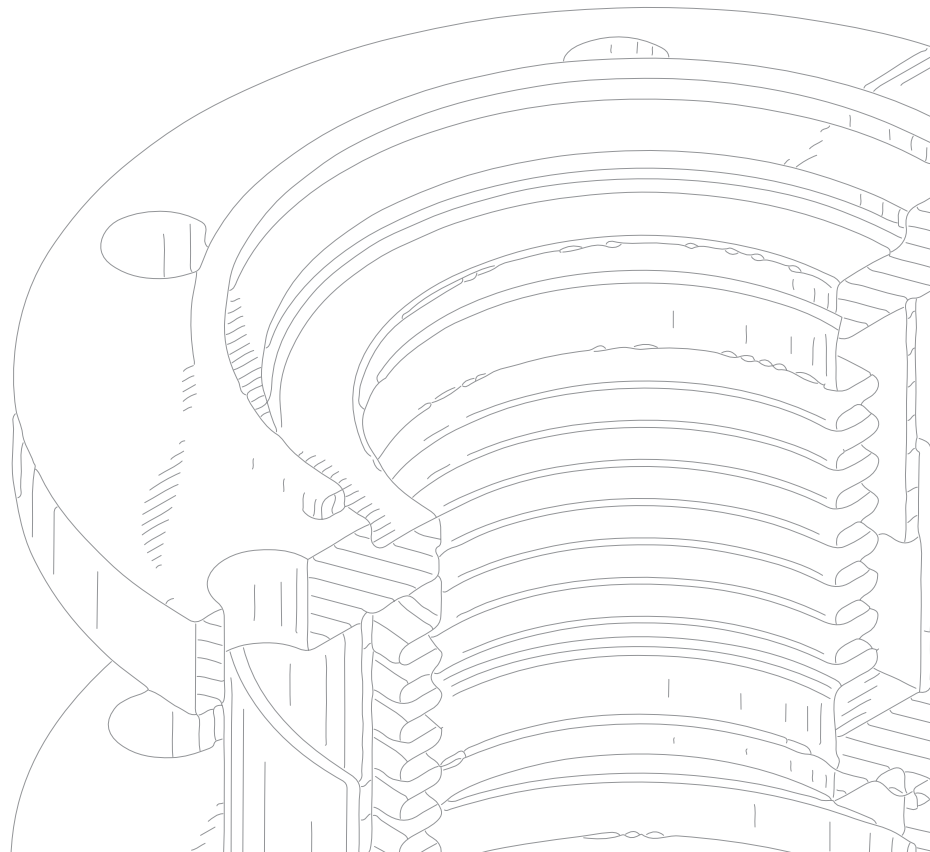
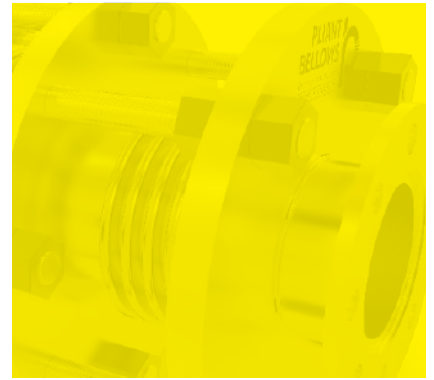
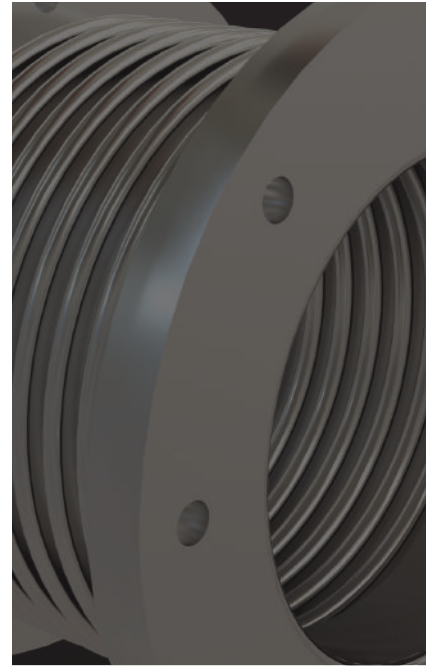

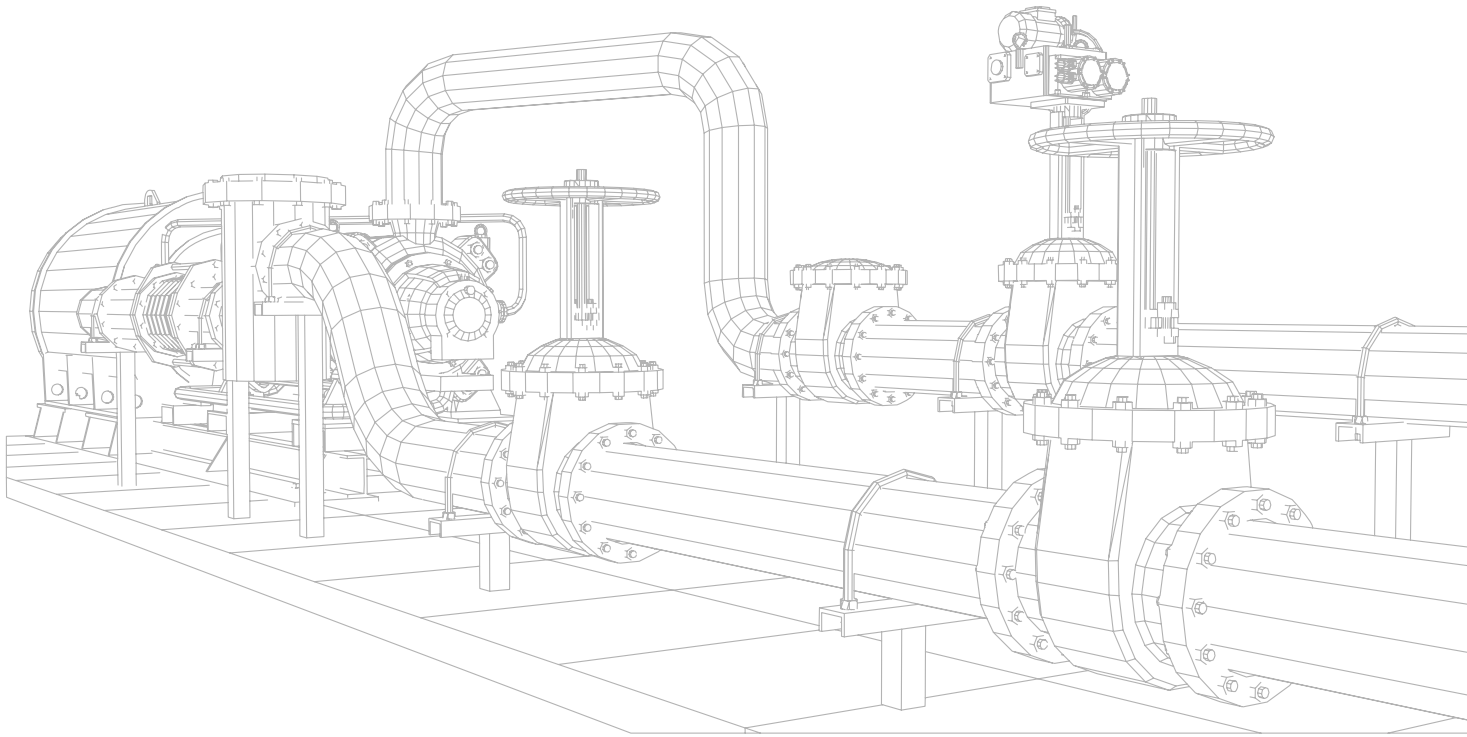

## About Company

Flexoresist Technologies Pvt. Ltd. is a pioneering entity in the Indian market, specializing in the design and manufacturing of innovative products previously domestically. Founded with the vision to fill the gap in the Indian market, Flexoresist embarked on its journey under the leadership of Mr. Anand Uttarkar, Industrial engineer with a Master's degree from Texas, USA.

### **Mission and Vision:**

At Flexoresist, our mission is to revolutionize the Indian engineering landscape by introducing cutting-edge products that cater to the evolving needs of various industries. We envision a future where indigenous innovation drives technological advancement and economic growth. under the brand name, "Pliant Bellows".

### **Technical Excellence:**

With a culture deeply rooted in technical

proficiency, Flexoresist prioritizes excellence in design, engineering, and manufacturing processes

### **Customer Satisfaction:**

We are committed to exceeding customer expectations by delivering superior quality products and unparalleled service.

### **Innovation:**

We are committed to exceeding customer expectations by delivering superior quality products and unparalleled service.

### **Products:**

Flexoresist stands as a leading authority in the design and manufacturing of the following products:

1. Metal Bellows and Expansion Joints
2. Metal O rings, C Rings, Spring Energized C Rings

---

## Business Philosophy & Strengths

- As the CEO and GM are technically qualified, the general orientation of the company is towards technical excellence .The work culture has also been developed accordingly.
  - The company implements, Kaizen (Continuous Improvement) and 5 S techniques to keep the entire system up to mark.
  - To facilitate all the above at operational level, experienced and qualified manpower has been employed.
  - The company has endeavoured to meet and achieve the quality standards set by the customers.
- 



## Systems And Certifications

Flexoresist Technologies Pvt. Ltd. is an ISO 9001:2015 certified company and is well supported by ERP software to maintain documentation. The entire tracking process, from incoming raw materials to dispatch is maintained reg

## Leadership



### **Mr. Anand Uttarkar**

Mr. Anand Uttarkar, the CEO, is a highly qualified engineer holding an M.S. degree in Industrial Engineering from Texas, USA. With over 23 years of experience in the industry, he has been instrumental in driving the organization toward excellence. His extensive expertise has contributed significantly to achieving the highest quality standards while implementing cost-effective solutions. Under his strategic leadership and vision, the organization has not only enhanced its operational efficiency but has also received numerous prestigious accolades and certifications, reinforcing its commitment to quality and innovation.

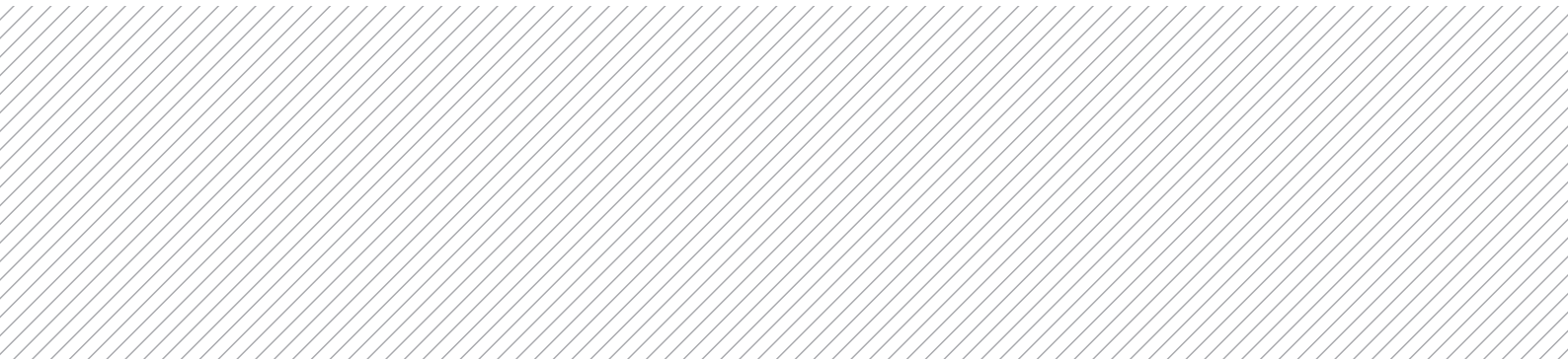

# Technology

## Hydro Forming Machine

The hydroforming machine is designed by US Designers and has been manufactured to international quality standards. Bellows formed by hydroforming process are uniform in structure with adequate dimensional accuracy. In a single step, corrugations are formed on an entire metal bellow, which increases the productivity considerably. The properties achieved by the hydroforming process are far superior as compared to mechanically drawn bellows. Metal bellows can be manufactured with a single ply or multiple plies with excellent flexibility, pressure tightness, and little wall thickness reduction.

Diameter range	[mm]	15 – 600
Ply thickness	[mm]	0.2 – 4
Tube length	[mm]	up to 1000
Internal pressure	[bar]	up to 340
Total Power	[HP]	25
Forming Time	[sec]	<60



## Punch Forming Machine

Metal bellows with diameters ranging from 90 mm to 1500 mm (New Machine is in development for bellows up to 6000 mm) can be processed on our Mechanical punch forming machine (also known as Mechanical Expander) which is also designed by US Designers. Single corrugation on the bellow is being formed mechanically. It's a two-step forming process, the first step is to form the tube into convoluted shape and the second step is the re-rolling process. The convolutions are punched individually thus eliminating thinning of bellow material. Metal bellows can be manufactured with a single ply or multiple plies. Internal and external diameters can be aligned as per customer's requirement.

Diameter range	[mm]	90 - 1500
Ply thickness	[mm]	<3 (single Ply), 5 Plies (1mm/ply)
Tube length	[mm]	<1500
Total power	[HP]	7.5
Forming Time/ convolution	[sec]	<60





## Products

### Axial Expansion Joints

These Joints are the simplest form of bellows manufactured. Pliant Bellows can manufacture them in single and multiple ply. Axial Expansion Joints can be provided with either flanges or pipe end connections. They are mostly used for axial movements. The advantage of axial expansion joints is the fact that they take up relatively little space and no directional changes in the piping are required. When installing axial expansion joints, proper fix points and guidance are required. Please consult our engineers for more information.

### Universal Expansion Joints

Universal expansion joints are made up of 2 elements of bellows joined together by a common spool piece so it is also called as Double Bellows Expansion Joint or Universal Bellows.

A Universal Expansion Joint is generally used where more lateral movement is to be absorbed which is beyond the capacity of a single Axial Expansion Joint and when there is a limitation on the amount of lateral forces allowed by the connecting pipe system. Universal expansion joints can take deflection in lateral, axial or angular movements.





## Lateral Expansion Joints

Lateral expansion joints refers to the direction perpendicular to the centre line of the pipe expansion joint. Lateral deflection is also called as Parallel Offset and Transverse. The lateral expansion joints are also known as tied lateral expansion joints or tied universal expansion joints.

In case of absorbing large amount of lateral deflections the universal expansion joints having two bellows are connected by a centre spool (piece of pipe) and the tie rods are then attached on the outer ends for maximum deflection absorption. In this type of expansion joints the length of centre spool (centre piece) plays a major role.

## Hinged Expansion Joints

When the angular movement is only in one plane, hinge or angular expansion joints are used. An angular expansion can be expressed when an expansion joint experience bending about its centre which is the centre line and half way between the ends of metal bellows.

These types of bellows are used mostly in sets wherever piping direction changes. So you will find hinged joints used at the locations where pipe bending occurs. Due to the hinged nature of this bellows only angular movement is allowed around the hinges.



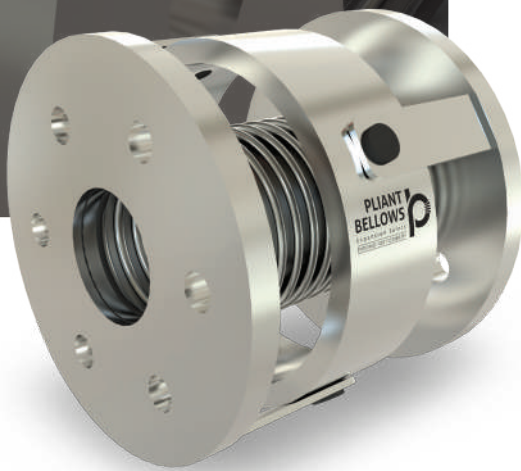

## Gimbal Expansion Joints

The gimbal expansion joints are the most reliable expansion joint since it is capable of absorbing angular motion in all the planes. Although single gimbal expansion joint can be used in isolation the most common applications use a pair of gimbal expansion joints to absorb a complex multi-plane motion in a piping system. Gimbal Expansion Joints are utilized in a pair to absorb the thermal expansion from two horizontal piping arms.

## Inline Pressure Balanced Expansion Joints

An inline pressure balanced expansion joint accommodates axial and lateral movements and counteracts the bellows pressure thrust. An additional bellow is incorporated into the unit and is subjected to the line pressure to generate a force equal and opposite to that on the main bellows. Tying these bellows together neutralizes the pressure load on the unit.

### Features:

- Does not transfer the thrust caused by the internal pressure to the pipes or adjacent equipment.
- Absorbs axial and lateral movements.
- Eliminates change in pressure.
- Pressure forces remain in balance.

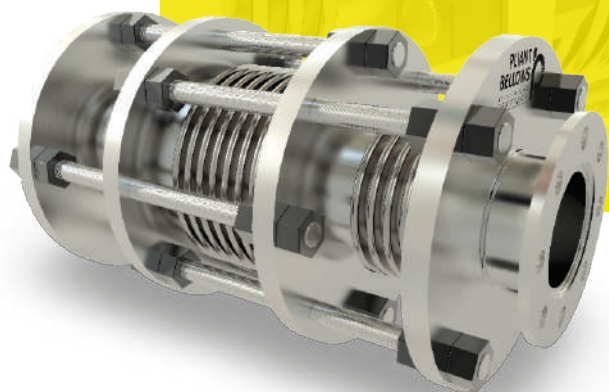
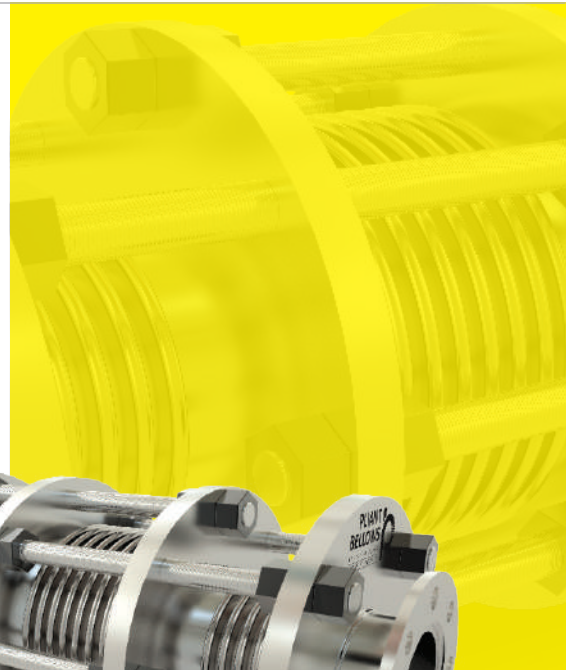



## Pressure Balanced (Elbow) Expansion Joints

An Elbow Pressure Balanced Expansion Joint is designed to absorb externally imposed axial movement without imposing pressure loading on the system. This is accomplished by using two bellows both at line pressure tied together and acting in opposite directions. It is used where pressure loading on piping or equipment is not acceptable. These expansion joints are usually installed at change of direction.

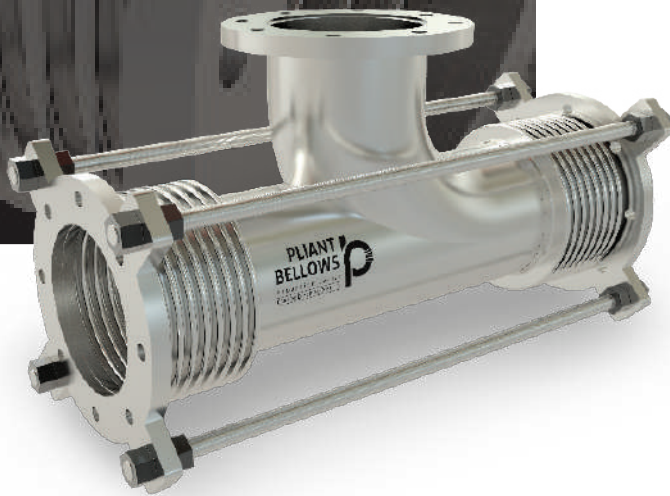

## Pressure Switch Bellows

Pressure switches are designed to make electrical contact when a set pressure is reached. These switches can be designed to close or open, based on the pressure rising or falling. Many industries use these types of switches to maintain optimum system operation.

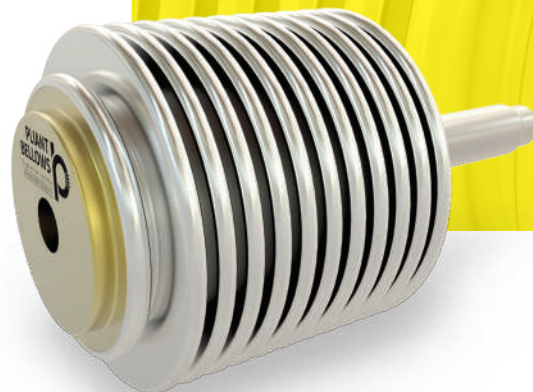
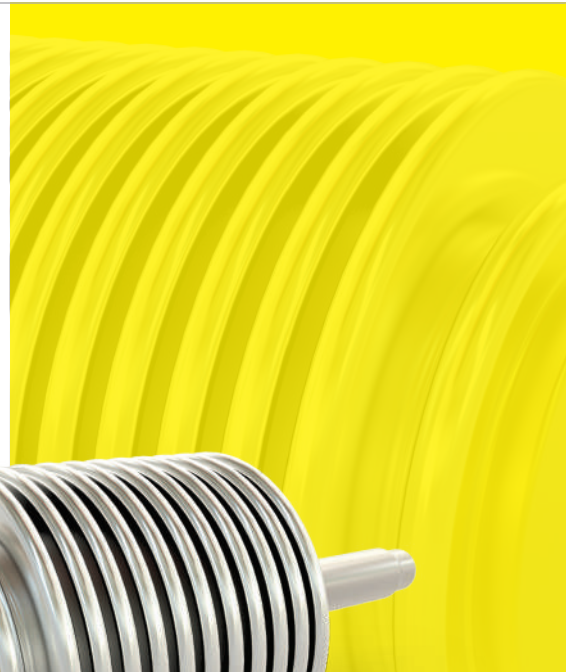



## Valve Bellows

Bellow sealed valves are a new type of Industrial Process valves. These valves are popular due to the leakage free performance hence, called “Zero Leak Valves” or “Emission Free Valves”.

With the application of Bellow seals the gland packing is supplemented by a metallic Bellow cartridge. One end of the Bellow is connected to the valve bonnet and the other end to the stem. The bellow movement is in one plane as the stroke in the valve takes place. With no rotational movements involved the fluid gets sealed to a very high degree. The fluid flows through the bottom part of the valve as per the stem movement takes place. Due to the bellow covering the stem the seal does not contact the stem at all. Hence, providing a leak free zone.

The life cycle of the metal Bellow is largely dependent on the process of bellow manufacturing. At Pliant Bellows we manufacture them by hydro forming process. The properties achieved by the hydro forming process are far superior as compared to mechanically drawn bellows. It is extremely important that the bellows have the mechanical and metallurgical properties for long cycle life of a bellow.

### Salient Features

Material	Stainless steel series, Brass, Bronze, Beryllium copper and Nickel based alloys like, Inconel, Hastelloy etc.
Size Range	10 NB – 1500 NB (Bigger size on special request)
Pressure Range	Up to 90 Bar (Higher pressure on special request)
Temperature Range	Cryogenic to 1200 °C
Shapes	Circular, Rectangular or other shapes on special request
No. of Ply	Single Ply, Heavy wall Single Ply, Multiply

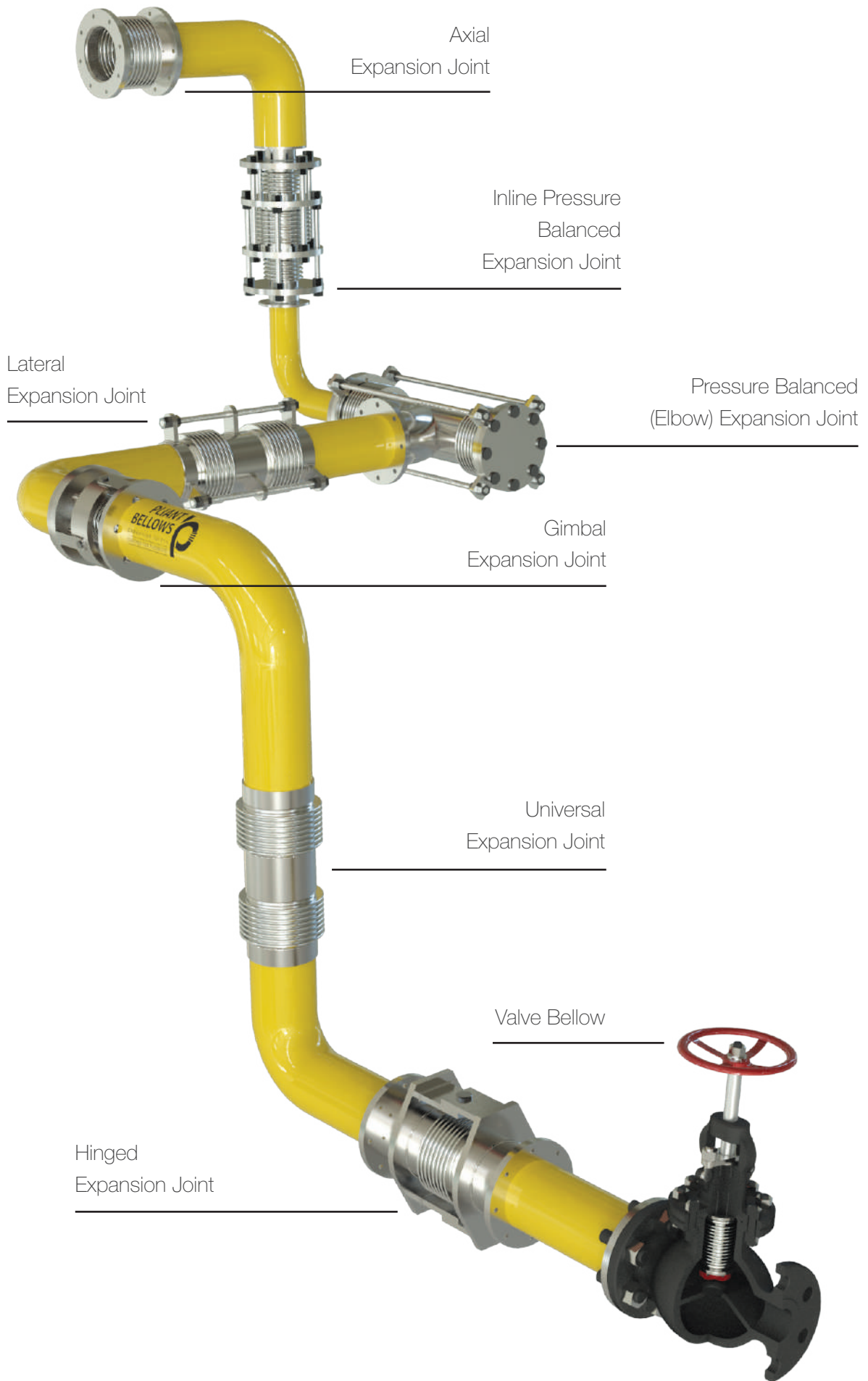

---

# Design And Manufacturing

The company has excellent capabilities in design and manufacturing of Expansion joints based on **EJMA 9th Edition**. The bellow design calculations are done by using competent software backed by rich experience of our designers. The designers use Autodesk fusion 360 CAD/CAM and have access to high end software's like SolidWorks.

The company understands the importance of having a well equipped tool room and inspection facility to support its production activities. Hence the company has invested in conventional and CNC machines from lathes, grinding to vertical machining centres. For the production activity the organisation has focused on developing SPM's as it believes that SPM's will help in achieving consistency, reliability and speed of manufacturing. Considering the future growth the company is planning to setup a new state of the art facility in the close vicinity.



---

## Applications

- Power Generation
- Sugar Mill
- Infrastructure
- HVAC
- Cryogenic
- Steel Industries
- Measurement & Control Systems
- Pulp & Paper
- Oil & Gas
- Engine Exhaust
- Solar Technology
- Chemical Industries
- Instrument & Valve Industries
- Water/ Waste Water
- Nuclear Plant
- Automobile Industries

---

## Testing Capabilities

- Hydrostatic Pressure and Leak Test
  - Pneumatic Bubble Soap Leak Test
  - Vacuum Test
  - Dye Penetrant Test
  - Visual Test
  - Fatigue Test
  - Squirm Test
  - Spring Rate Test
  - Radiography Test (Through third party approved vendors)
  - X-Ray Test (Through third party approved vendors)
  - Ultrasonic Test (Through third party approved vendors)
  - Helium Leak Detection Test (Through third party approved vendors)
-

## PLIANT BELLOWS DATASHEET

Website: [www.pliantbellows.com](http://www.pliantbellows.com) |  
Tele: +91-7028997949 /+91-9890454224

Customer : _____ Sr.No: _____ Date: _____																																																								
Email ID: _____ Mob. No.: _____ PO. No.: _____																																																								
Type of Bellow	Circular : _____ Rectangular : _____ Other : _____ Quantity : _____ Size (NB/DN): _____ Other Length: _____																																																							
Installation	Vertical : _____ Horizontal : _____ Universal : _____																																																							
Bellow Material	Material : _____ No. of Ply : _____ Ply Thickness : _____																																																							
Liner / Sleeve	Yes : _____ No.: _____ Ply Thk : _____ Material : _____ Length : _____																																																							
End Fitting	<table border="1"> <thead> <tr> <th></th> <th>1<sup>st</sup></th> <th>2<sup>nd</sup></th> <th>Hole Dia.</th> <th>No.of Holes</th> </tr> </thead> <tbody> <tr> <td>Fix Flange</td> <td></td> <td></td> <td></td> <td></td> </tr> <tr> <td>Rotating Flange</td> <td></td> <td></td> <td></td> <td></td> </tr> <tr> <td>Weld End</td> <td></td> <td></td> <td></td> <td></td> </tr> <tr> <td>Material</td> <td></td> <td></td> <td></td> <td></td> </tr> <tr> <td>ID(I/S)</td> <td></td> <td></td> <td></td> <td></td> </tr> <tr> <td>OD(O/S)</td> <td></td> <td></td> <td></td> <td></td> </tr> <tr> <td>PCD (CD)</td> <td></td> <td></td> <td></td> <td></td> </tr> <tr> <td>Thk.</td> <td></td> <td></td> <td></td> <td></td> </tr> <tr> <td>RF</td> <td></td> <td></td> <td></td> <td></td> </tr> <tr> <td>RF Depth</td> <td></td> <td></td> <td></td> <td></td> </tr> </tbody> </table>		1 <sup>st</sup>	2 <sup>nd</sup>	Hole Dia.	No.of Holes	Fix Flange					Rotating Flange					Weld End					Material					ID(I/S)					OD(O/S)					PCD (CD)					Thk.					RF					RF Depth				
		1 <sup>st</sup>	2 <sup>nd</sup>	Hole Dia.	No.of Holes																																																			
	Fix Flange																																																							
	Rotating Flange																																																							
	Weld End																																																							
	Material																																																							
	ID(I/S)																																																							
	OD(O/S)																																																							
	PCD (CD)																																																							
	Thk.																																																							
RF																																																								
RF Depth																																																								
Movements	Axial (+/-) : _____ Lateral (+/-) : _____ Angular (+/-) : _____																																																							
Spring Rates	Axial : _____ Lateral : _____ Angular: _____																																																							
Temperature	Operating : _____ Design : _____																																																							
Pressure	Operating : _____ Design : _____																																																							
Media	Media : _____ Flow Velocity: _____ Flow Direction: _____																																																							
No. of Tie / Limit Rod	Yes : _____ No: _____ Material : _____ Size : _____ Quantity : _____																																																							
Notes :																																																								

(Add Units)

Email ID - [mktg@pliantbellows.com](mailto:mktg@pliantbellows.com)

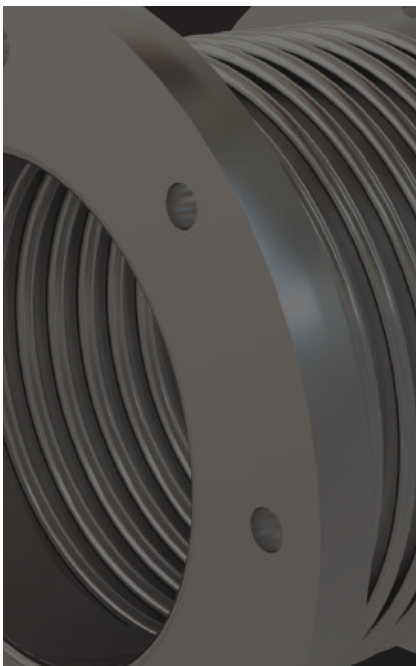
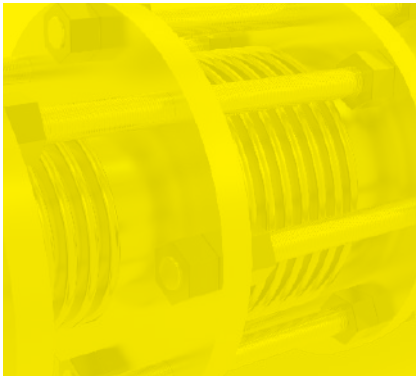
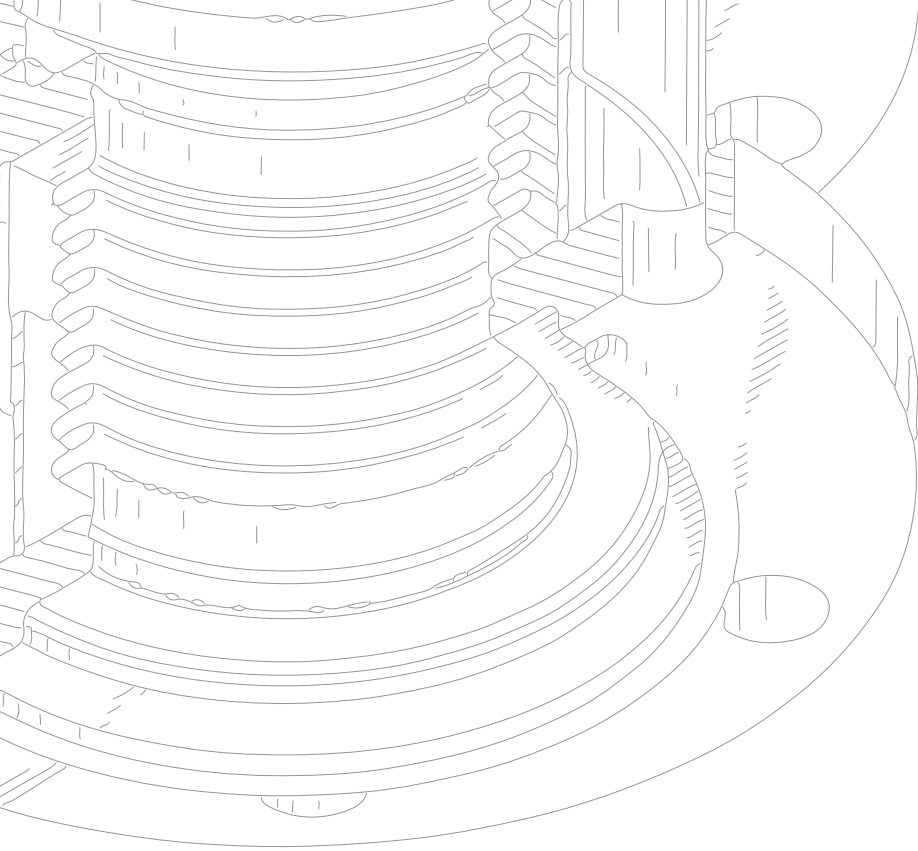



FLEXORESIST TECHNOLOGIES PVT. LTD.

ISO 9001:2015

#### Corporate Office

Final plot no.38/1 Ramtekdi  
Industrial Estate, Hadapsar, Pune,  
Maharashtra, India- 411013

#### Phone

+91-70289 97949  
+91-98904 54224  
+91-73876 43943

#### Email

mktg@pliantbellows.com  
anand.uttarkar@flexoresist.com  
sales@flexoresist.com

**Website:** [www.pliantbellows.com](http://www.pliantbellows.com)

